

## Section 2

# Engine Control Systems

**Overview** The 1NZ-FXE engine is optimized for its role as one of two sources of motive power in the Prius. The system controls the distribution of the engine and motor drive energy and the most efficient engine operation zone will automatically be selected. The engine may stop automatically when the vehicle is starting out and traveling at low speed to reduce fuel consumption and emissions.

**Atkinson Cycle** The Prius engine operates on the Atkinson Cycle, which allows the compression and expansion ratios to be independently set. The Atkinson Cycle engine achieves high thermal efficiency and has a high expansion ratio cycle. When the Atkinson Cycle is combined with the VVT-i system, it provides the benefits of a variable stroke engine. In the fully retarded position, the effective compression stroke nearly matches the power stroke. Late closing of the intake valve causes the compression stroke to begin later. The disadvantage is that positive pulses are discharged into the intake manifold resulting in low intake manifold vacuum. The power stroke remains the same allowing a longer amount of time to capture the energy of the expanding gases.

### Engine Components

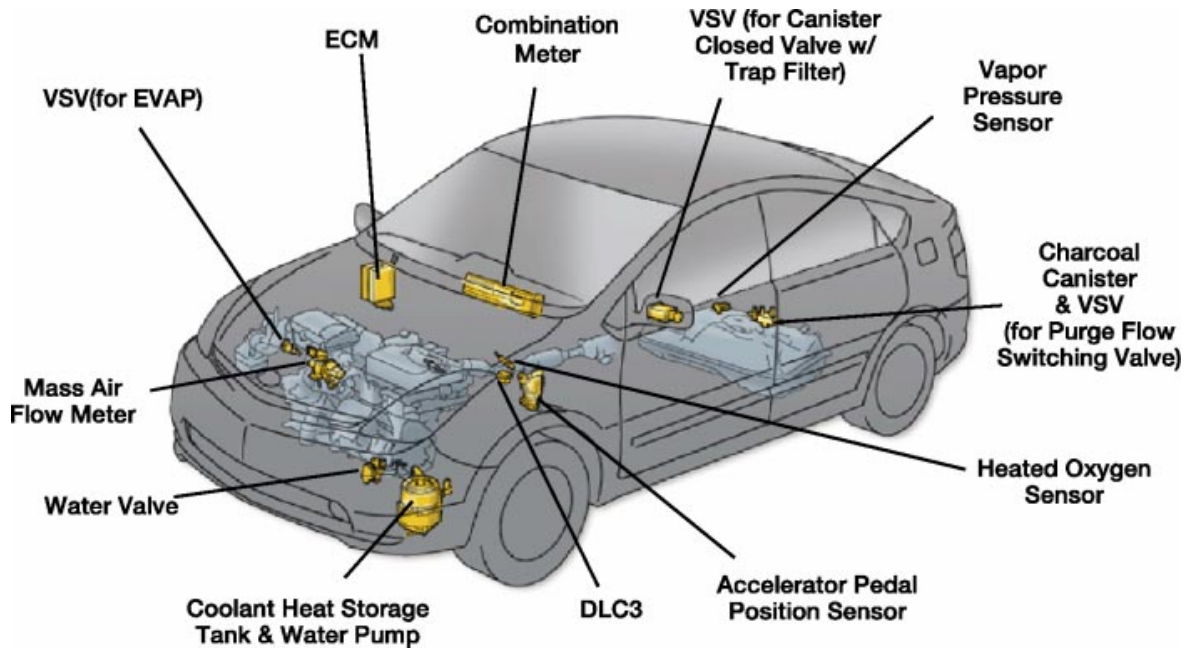

Figure 2.1

T072f201c

## Engine Control System Sensors

**Mass Air Flow Meter** The Mass Air Flow Meter uses a platinum hot wire and a control circuit installed in a plastic housing. The meter is mounted in the air inlet just above the throttle body.

The hot wire is in the circuit that measures the amount of air entering the engine intake. The temperature of the hot wire is maintained at a constant value by controlling the current flow through the hot wire. Incoming air tends to cool the hot wire. As airflow increases, current flow through the wire is also increased to maintain the hot wire set temperature. This current flow is then measured and reported to the ECM as the output voltage of the air flow meter.

**Intake Air Temperature Sensor** The Intake Air Temperature Sensor is built into the Mass Air Flow Meter and senses the temperature of intake air. An NTC Thermistor changes resistance as the intake air temperature changes. As intake air temperature increases, the Thermistor resistance value and the signal voltage to the ECM decrease.

**Engine Coolant Temperature Sensor** The Engine Coolant Temperature Sensor is located in the engine block and senses the temperature of the engine coolant. An NTC Thermistor changes resistance as the coolant temperature changes. As coolant temperature increases, the Thermistor resistance value and the signal voltage to the ECM decrease.

**Accelerator Pedal Position Sensor** The Accelerator Pedal Position Sensor is mounted on the accelerator pedal assembly. Two separate Hall Effect sensors are used to detect accelerator pedal position. Due to the characteristics of the Hall elements, different signals are output depending on whether the pedal is being depressed or released. The HV ECU receives the signals and compares them for reliability.

**Throttle Position Sensor** The Throttle Position Sensor is mounted on the throttle body and converts the throttle valve opening into two electrical signals which are inputs VTA and VTA2 to the ECM. The signals have different voltage values. The ECM compares the two output signals from the two sensors for reliability.

The ECM drives the throttle control motor by determining the target throttle valve opening in response to driving conditions.

- Idle Speed Control** Engine idle speed is controlled entirely by throttle valve opening and the ETCS-i. No separate idle speed control system is required. The system includes idle-up control during cold engine operation, intake air volume control to improve the startability of the engine and load compensation for changes such as when the A/C is turned ON or OFF.
- Knock Sensor** The Knock Sensor is mounted on the cylinder block and detects detonation or knocking in the engine. This sensor contains a piezoelectric element which generates a voltage when it becomes deformed. Cylinder block vibrations due to knocking deform the sensor element. If engine knocking occurs the ignition timing is retarded to suppress it.
- Crankshaft Position Sensor** The Crankshaft Position Sensor (NE signal) consists of a toothed signal plate and an inductive pick up coil. The signal plate has 34 teeth, with one gap created by missing teeth. The plate is mounted on the crankshaft. The NE sensor generates a 34-pulse waveform for every crankshaft revolution. Since this is an inductive sensor, both the frequency and amplitude of the generated signal increase with increasing engine rpm. The ECM uses the NE signal to determine engine rpm and also for misfire detection.
- Camshaft Position Sensor** The Camshaft Position Sensor (G2 signal) consists of a signal plate with a single tooth and a pick up coil. The G2 signal plate tooth is on the exhaust camshaft. The G2 sensor generates one-pulse waveform for every revolution of the exhaust camshaft. Since this is an inductive sensor, both the frequency and amplitude of the generated signal increase with increasing engine rpm. The ECM uses the G2 signal to determine the position of the no.1 piston for the ignition firing order.
- Heated O2 Sensors** The O2 Heater Control maintains the temperature of the O2 Sensors at an appropriate level to increase accuracy of detection of the oxygen concentration in the exhaust gas. On the '01-'03 Prius, the sensors include:
- Bank 1, Sensor 1\*
  - Bank 1, Sensor 2\*
- \*Sensor 1 - refers to the sensor ahead of the catalytic converter. This sensor measures the oxygen content of the engine exhaust gases. The ECM uses this input to adjust fuel trim.
- \*Sensor 2 - refers to the sensor after the catalytic converter. This sensor is used to measure catalyst efficiency.

Note: The '04 and later Prius includes several new DTCs for the Bank 1 Sensor 2 Oxygen Sensor:

- P0136 - Oxygen Sensor Circuit Malfunction
- P0137 - Oxygen Sensor Circuit Low Voltage
- P0138 - Oxygen Sensor Circuit High Voltage

### Air/Fuel Ratio Sensor

On the '04 and later Prius, the Bank 1 Sensor 1 O<sub>2</sub> Sensor is replaced by an A/F Sensor. The A/F Sensor detects the air/fuel ratio over a wider range, allowing the ECM to further reduce emissions.

The A/F Sensor used is the planar type. Compared to the conventional cup type, the sensor and heater portions of the planar type are narrower overall. Because the heat of the heater acts directly on the alumina and zirconia it accelerates the activation of the sensor.

### Cooling System

The engine cooling system is a pressurized, forced-circulation type. A thermostat with a bypass valve is located on the water inlet housing to control coolant flow and maintain suitable temperature distribution in the cooling system. The flow of engine coolant makes a U-turn in the cylinder block to ensure even heat distribution. The radiator for the engine and the A/C condenser have been integrated to minimize space requirements.

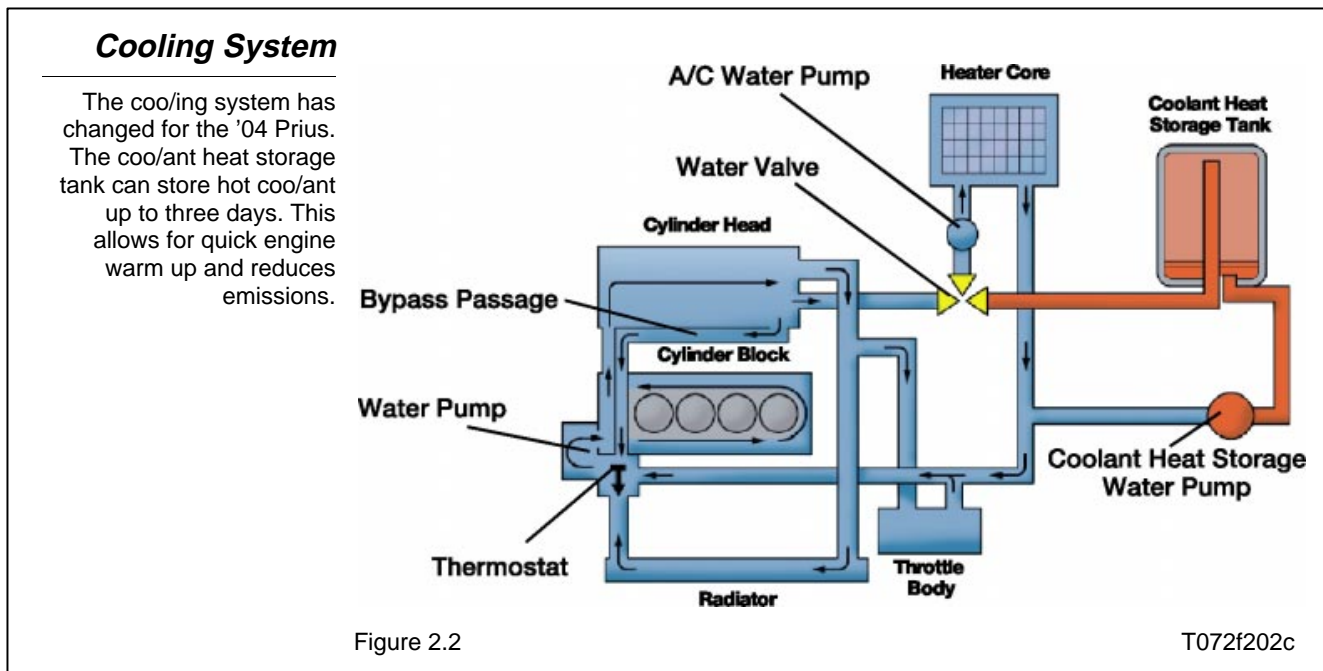

**Coolant Heat Storage**

Starting on the '04 Prius, the cooling system includes a Coolant Heat Storage Tank that can store hot coolant at 176°F for up to three days. When starting a cold engine the system uses an auxiliary water pump to force the hot coolant into the engine. This 'preheating' of the engine reduces HC exhaust emissions.

**DTC P1151 Coolant Heat Storage Tank**

For DTC P1151, the Repair Manual recommends replacing the coolant heat storage tank. But there is also a note in the manual pointing out that this DTC can be set if there are air bubbles in the system.

Note: To avoid replacing the tank unnecessarily, check for the sound of air bubbles flowing through the heater core, which can be heard from the passenger compartment. If air bubbles are present, bleed the air from the system following the Repair Manual instructions. Clear the code and drive the vehicle for two trips. The code should not return. If it does, *then* you should replace the coolant heat storage tank.

**Coolant Heat Storage Tank**

The storage tank is a large vacuum insulated container located near the left front bumper.

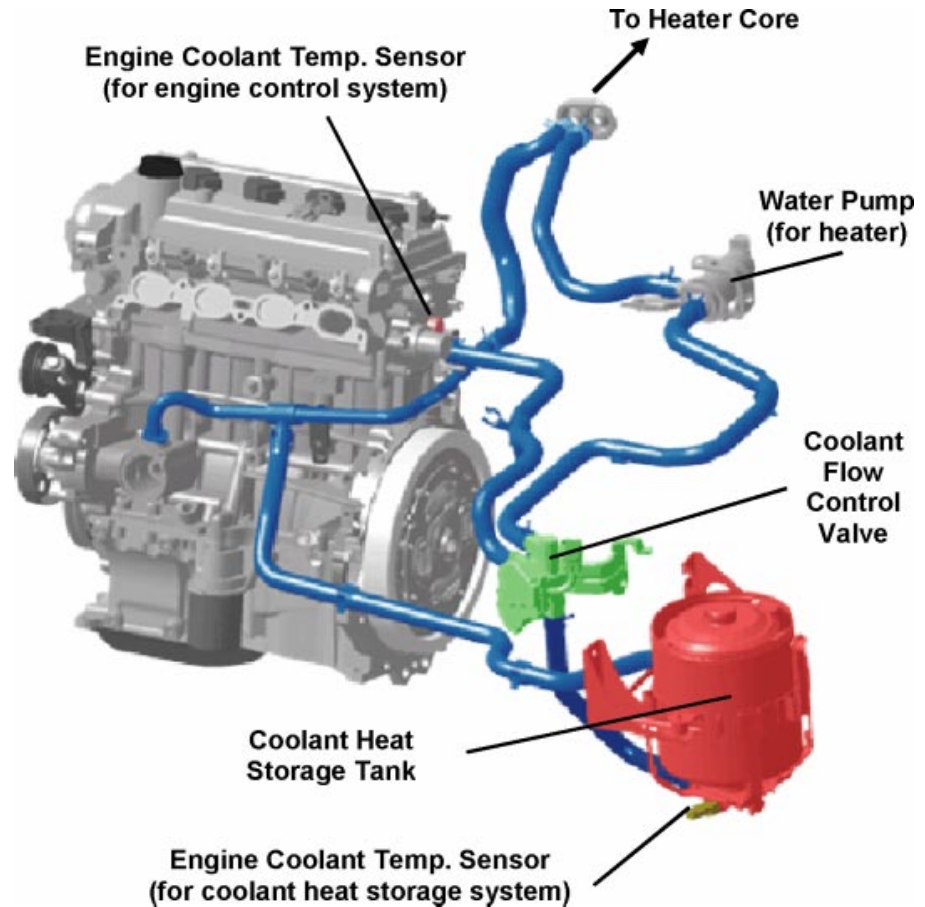

Figure 2.3

T072f203c

**Coolant Heat  
Storage Tank**

Coolant Drain Plug

Outlet Temp Sensor



Figure 2.4

T072f204p

**Coolant Heat  
Storage Tank**

Water Pump



Figure 2.5

T072f205p

**SERVICE TIPS**

When servicing the coolant system on the '04 and later Prius:

- Disconnect the coolant heat storage water pump connector
- Drain the engine coolant
- Operate the coolant heat storage water pump when refilling to help the inflow of coolant into the tank

**Rotary Water Valve**

Switches between three positions to control flow of coolant in and out of coolant heat storage system.

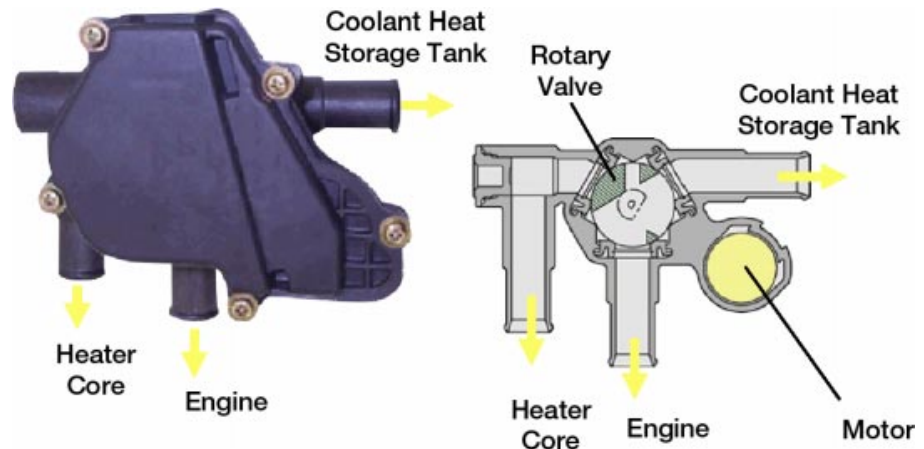

Figure 2.6

T072f206c

**Water Valve Positions**

Position	Purpose	V DC
Water Flow Valve (VLV)3	Preheat & Storage after Power OFF	2.5V
Water Flow Valve (VLV)4	Storage after Engine ON	3.5V
Water Flow Valve (VLV)5	Engine Warm Up	4.5V

**DTC P0300  
Random/Multiple  
Cylinder Misfire**

The ECM uses the crankshaft position sensor and camshaft position sensor to monitor changes in the rate of crankshaft rotation as each cylinder fires. The crankshaft accelerates when a cylinder fires and slows down if the cylinder misfires. The ECM counts the number of times that the crankshaft slows down and then indicates that a misfire has occurred. When the misfire rate equals or exceeds the count indicating that the engine condition has deteriorated, the MIL illuminates. If the misfire rate is high enough and the driving conditions will cause catalyst overheating, the MIL blinks when misfire is detected. Below are some basic tips when diagnosing a vehicle with DTC P0300.

Get details from the customer:

- When did the MIL illuminate?
- Did the customer recently refuel? What brand and octane of fuel did they purchase?

**NOTE**

The Prius is designed to run on 87 octane. The use of premium fuel may cause starting problems.

- With the Diagnostic Tester check and record DTCs and Freeze Frame data.
- Evaluate engine performance while monitoring the Diagnostic Tester. Refer to the DI section of the repair manual to further diagnose symptoms.

<b>Misfire DTCs</b>	<b>DTC No.</b>	<b>DTC Detecting Condition</b>	<b>Trouble Area</b>
When two or more codes for misfiring cylinders are recorded repeatedly, but no random misfire code is recorded, it indicates that the misfires were detected and recorded at different times.	P0300 P0301 P0302 P0303 P0304	Misfiring of random cylinders is detected during any particular 200 or 1,000 revolutions. For any particular 200 revolutions for the engine, misfiring is detected which can cause catalyst overheating (This causes the MIL to blink)	<ul style="list-style-type: none"> <li>• Open or short in engine wire</li> <li>• Connector connection</li> <li>• Vacuum hose connection</li> <li>• Ignition system</li> <li>• Injector</li> <li>• Fuel pressure</li> <li>• Manifold absolute pressure sensor</li> <li>• Engine coolant temp. sensor</li> <li>• Compression pressure</li> <li>• Valve clearance</li> <li>• Valve timing</li> <li>• ECM</li> <li>• PCV piping</li> </ul>

**DTC P1128  
Throttle Control  
Motor Lock  
Malfunction**

The throttle motor opens and closes the throttle valve on commands from the ECM. The opening angle of the throttle valve is detected by the throttle position sensor which is mounted on the throttle body. This sensor provides feedback to the ECM in order for the throttle valve opening angle to properly respond to the driving condition. If DTC P1128 is stored, the ECM shuts down the power to the throttle motor and the throttle valve is fully closed by the return spring.



**DTC P3190 Poor Engine Performance & DTC P3191 Engine Does Not Start**

The ECM receives data from the HV ECU such as engine power output requirement (required output), estimated torque produced by the engine (estimated torque), target engine RPM, and whether the engine is in start mode or not. Then, based on the required output and target RPM, the ECM calculates a target torque that is to be produced by the engine and compares it with the estimated torque. If the estimated torque is low compared to the target torque or if the engine start mode continues at the engine RPM for the duration calculated by water temperature, an abnormal condition is detected.

Some 2001 and 2002 Prius may exhibit a Master, Hybrid and MIL warning if low engine power output is detected during a particular THS drive cycle. After starting the car (READY light ON), P3191 and P3101 with Information Code 205 may set in the engine ECM. After the READY light is ON and the vehicle has transitioned from an electric drive mode to one where the engine power is required, P3190 and P3101 with Information Code 204 may set in the engine ECM and the HV ECU.

**Out of Fuel**

Many factors can prevent the engine from starting, including the Fuel Injection System, Ignition System, Engine Compression, Air Induction System, and Fuel Quality (Unleaded fuel only). But one of the most common causes is simply running out of gas. Running out of gas on the Prius can cause any of the following DTCs:

- P3190 - Poor Engine Power
- P3191 - Engine Does Not Start
- P3193 - Fuel Run Out
- P0A0F - Engine Failed To Start

**NOTE**

The codes listed above may be recorded alone or in combination.

**NOTE**

If the injectors need to be replaced remember to bleed fuel pressure! If the pressure is not bled the fuel will drain into cylinders and hydrolock will occur!

**HC Adsorption Catalyst System (HCAC)**

The purpose of the HCAC system on the Prius is to adsorb and retain unburned hydrocarbons (HC) in the exhaust produced by the engine during and following a cold start. The stored HC is then released and purged through the warm three-way catalyst. This improves exhaust emissions at low temperatures.

In the front three-way catalytic converter (TWC) the ceramic matrix wall thickness has been reduced and the passage density increased. This decreases thermal mass and speeds the heating of the catalyst.

**Operation** Before the engine is started, the bypass valve is open. When the engine is started the ECM outputs a signal to the HCAC VSV. Vacuum is applied to the HCAC actuator, closing the bypass valve. Immediately after the engine has started the exhaust gases pass through the HC adsorber where HC is stored until the temperature of the HC adsorber rises. This prevents HC from being emitted when catalyst temperatures are low.

After the TWC has warmed up, the VSV closes and the bypass valve opens. Stored HC is now purged and flows through the TWC where it is oxidized.

During deceleration, the VSV is turned on, closing the bypass valve. This scavenges HC that remains in the HC adsorber.

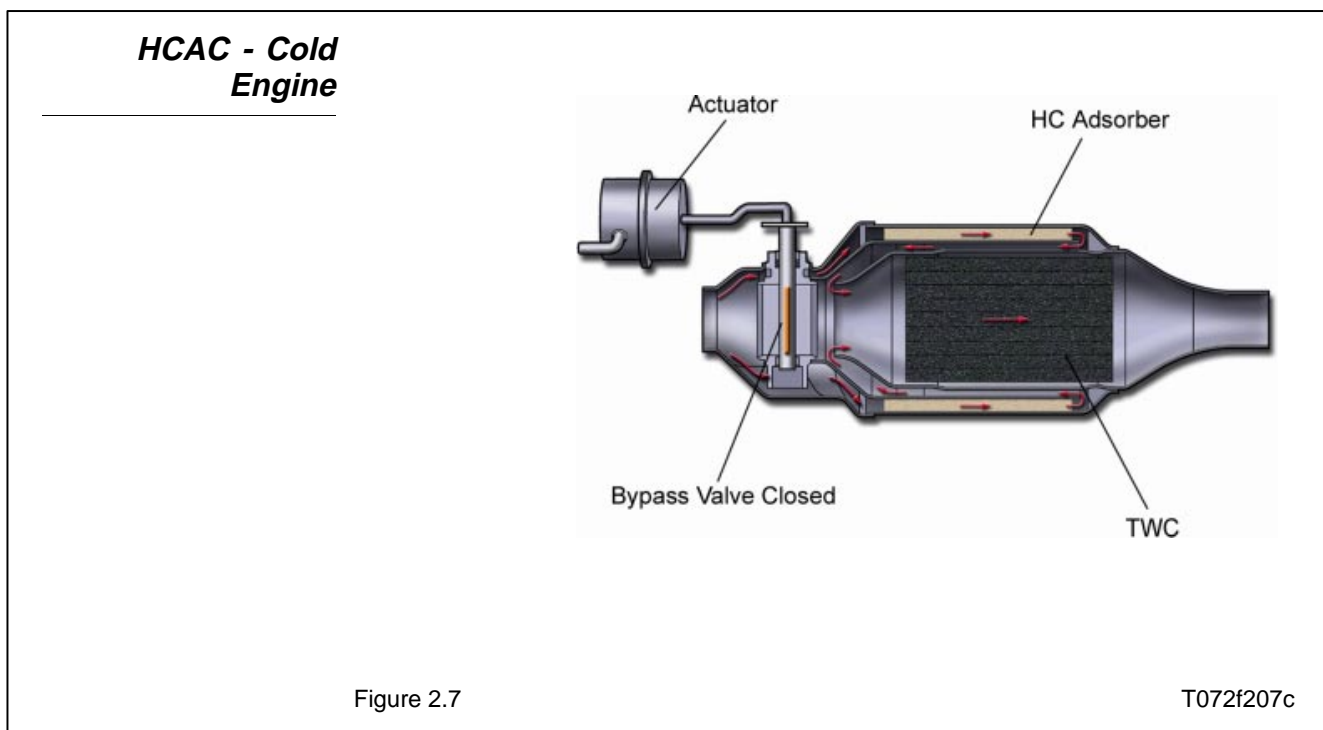

**HCAC - Purge**

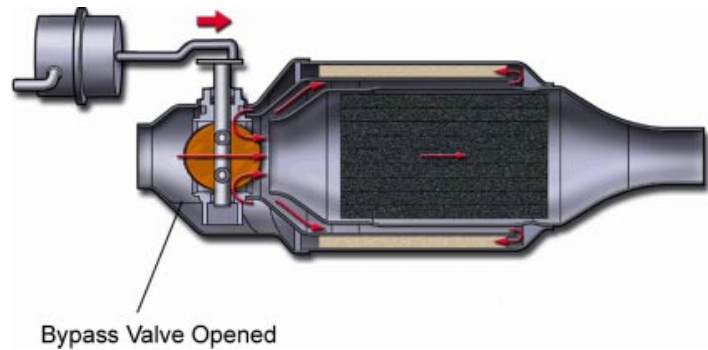

Figure 2.8

T072f208c

**HCAC - Scavenge  
During  
Deceleration**

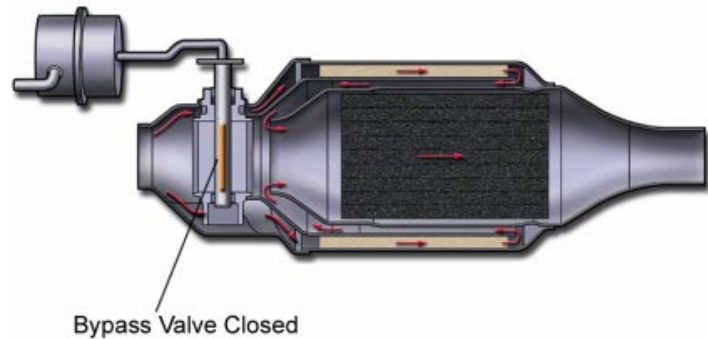

Figure 2.9

T072f209c

**DTC P1436  
Bypass Valve  
Malfunction**

The system monitors bypass valve operation. DTC P1436 will set if the bypass valve does not perform normally under the following conditions. During a cold start (with coolant and air temperatures starting at -10°C (14°F) to 40°C (104°F) and after coolant temperature has reached at least 45°C (113°F) and the engine load factor exceeds 30%.

**Repair Process** Certain 2001 and 2002 model year Prius vehicles that are operated in areas where road salt is used may set DTC P1436. Check the HCAC bypass valve for smooth operation. The front exhaust pipe assembly may have to be replaced if any shaft binding is evident.

**DTC P0420 Catalyst System Efficiency** The ECM compares the waveform of the O2 Sensor located before the catalyst (Bank 1, Sensor 1) with the waveform of the O2 Sensor located behind the catalyst (Bank 1, Sensor 2) to determine whether or not catalyst performance has deteriorated.

**Below Threshold** A/F ratio feedback compensation keeps the waveform of the O2 Sensor before the catalyst repeatedly changing back and forth from rich to lean.

If the catalyst is functioning normally, the waveform of the O2 Sensor behind the catalyst should be flat and should not mimic the front O2 Sensor. When both waveforms change at a similar rate, it indicates that catalyst performance has deteriorated.

Ask the customer if they have driven through deep water. If the catalyst is submerged, cooling will affect efficiency.

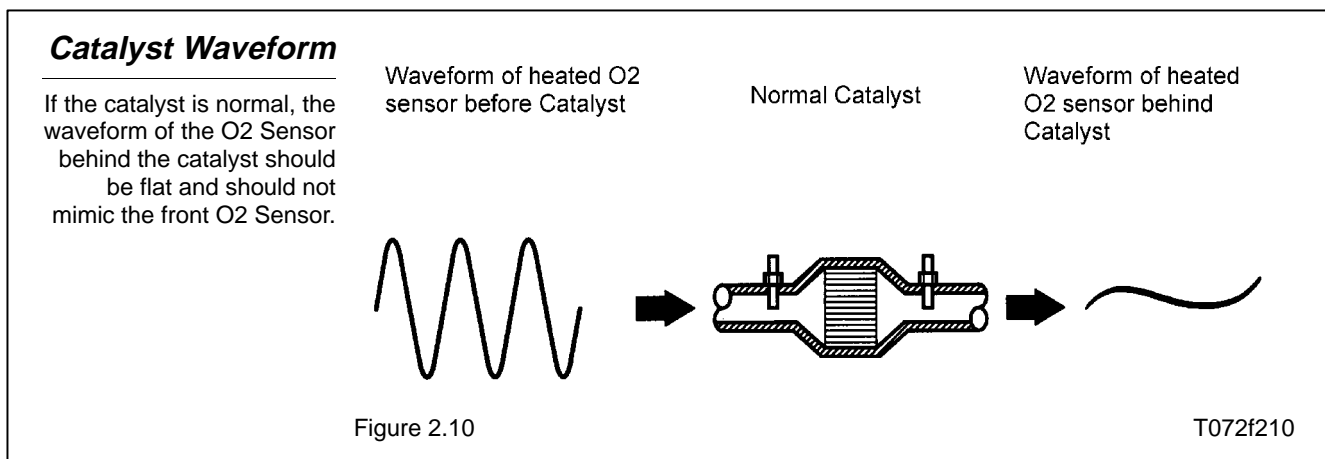

**OX Signal Waveform** Drive the vehicle at >55 mph for >5 minutes. Confirm that the waveform of O2 Sensor, Bank 1 Sensor 1 (OX1) oscillates around 0.5V during feedback to the ECM and that the waveform of O2 Sensor, Bank 1 Sensor 2 (OX2) is relatively constant at 0.6V to 0.7V.

**HINT**

There are some cases where even though a malfunction exists the MIL may not illuminate. Normal waveform of OX2 is a smooth line of 0.6V or 0.7V.

Check for an open or short in the harness and connector between both heated O2 Sensors and the ECM. If the problem still occurs replace the three-way catalytic converter.

### ***OX Signal Waveform***

If there is a malfunction in the system, the waveform of the O2 Sensor, Bank 1 Sensor 2 (OX2) will look similar to the waveform shown here.

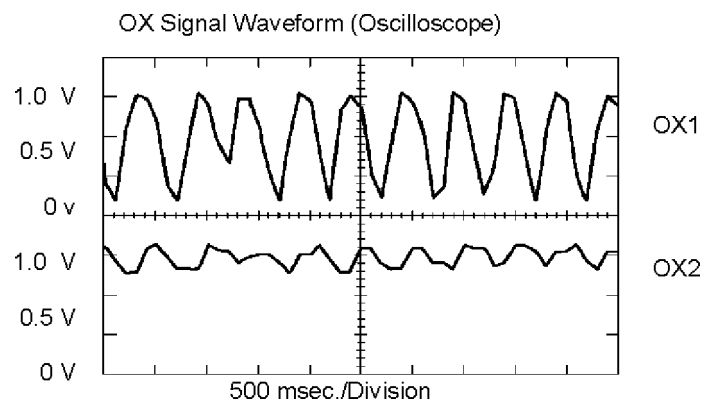

Figure 2.11

T072f211

### **Normal Engine Operating Conditions**

When using the Diagnostic Tester to determine engine control status, refer to the Normal Engine Operation Conditions chart for quick and easy diagnosis. This chart is located in the Appendix of this book.

The values given for “Normal Conditions” are representative values. A vehicle’s engine may still be normal even if its values vary from those listed.

### **OBID Diagnostic Trouble Codes**

The diagnostic system in the Prius performs a variety of functions. The first function is the Diagnostic Trouble Code Check. This test detects malfunctions in the signal circuits connected to the ECU. These malfunctions are stored in ECU memory at the time of the occurrence and are output by the technician during troubleshooting.

Another function is the Input Signal Check which checks to see if signals from various switches are correctly sent to the ECU. By using these check functions the problem areas can be narrowed down quickly and troubleshooting can be performed effectively. Diagnostic functions are incorporated in the following systems in the Prius.

**System  
Confirmation and  
Diagnostic Trouble  
Code Check**

System	Diagnostic Trouble Code Check	Input Signal Check (Sensor Check)	Diagnostic Test Mode (Active Test)
SFI System	<input type="radio"/> (w/ Check Mode)	<input type="radio"/>	<input type="radio"/>
Hybrid Control System	<input type="radio"/>		<input type="radio"/>
HV Battery System	<input type="radio"/>		<input type="radio"/>
Electronically Controlled Brake System	<input type="radio"/>	<input type="radio"/>	<input type="radio"/>
Shift Control System (Parking Lock Control)	<input type="radio"/>		
Electronic Power Steering System	<input type="radio"/>	<input type="radio"/>	
Air Conditioning System	<input type="radio"/>		<input type="radio"/>
Supplemental Restraint System	<input type="radio"/>	<input type="radio"/>	
Audio System	<input type="radio"/>	<input type="radio"/>	
Navigation System		<input type="radio"/>	
Power Window Control System	<input type="radio"/>		<input type="radio"/>
Power Door Lock Control System	<input type="radio"/>		<input type="radio"/>
Smart Entry System			<input type="radio"/>
Wireless Door Lock Control System	<input type="radio"/>		<input type="radio"/>
Engine Immobilizer System	<input type="radio"/>		<input type="radio"/>
Push Button Start System	<input type="radio"/>		<input type="radio"/>
Multiplex Communication System	<input type="radio"/>		
CAN Communication System	<input type="radio"/>		<input type="radio"/>
Cruise Control System	<input type="radio"/>		<input type="radio"/>

When performing the Diagnostic Trouble Code check it is important to determine whether the problem indicated by the DTC is present or occurred in the past and has returned to normal. The DTC should be checked before and after the symptom confirmation to determine the current conditions as shown in the following figure.

If this procedure is not followed it may result in unnecessary troubleshooting for normally operating systems, make it more difficult to locate the problem or cause unnecessary repairs. Always follow the procedure in the correct order and perform the DTC check.

**Diagnostic Trouble Code Check Procedure**

Diagnostic Trouble Code Chart (make a note of DTC and then clear)	Confirmation of Symptoms	Diagnostic Trouble Code Check	Problem Condition
Diagnostic Trouble Code Display	Problem symptoms exist	Same DTC is displayed	Problem still occurring in the diagnostic circuit
	No problem symptom exists	Normal code is displayed	Problem still occurring in a place other than in the diagnostic circuit (The DTC displayed first is either for a past problem or it is a secondary)
Problem occurred in the diagnostic circuit in the past			
Normal code display	Problem symptoms exist	Normal code is displayed	Problem still occurring in a place other than in the diagnostic circuit
	No problem symptom exists	Normal code is displayed	Problem occurred in a place other than in the diagnostic circuit in the past

**DTC Cycles** OBD II Trouble Codes have been standardized by the SAE. They indicate the circuit and the system in which a fault has been detected. When a malfunction occurs and meets the criteria to set a DTC, the MIL illuminates and remains illuminated as long as the fault is detected. Once the condition returns to normal the MIL will be turned off after 3 warm-up cycles. The DTC remains stored for 40 drive cycles. After 40 cycles the code will automatically be erased, but will remain in ECM history until cleared.

**Data List & Extended Data List** When selecting **OBD/MOBD** the **Data List** mode located under the **Engine and ECT** screen provides access to current engine related data. All input values displayed are current values. Extended Data is also available under the same **Engine and ECT** screen. This mode contains even more engine related real-time data.



**Data List vs.  
Extended Data List**

The Extended Data List contains more diagnostic information.

**Data List**

INJECTOR.....	0.0ms
IGN ADVANCE.....	5.0deg
CALC LOAD.....	0%
MAF.....	0gm/s
ENGINE SPD.....	0rpm
COOLANT TEMP.....	145.4°F
INTAKE AIR.....	98.6°F
THROTTLE POS.....	14%
VEHICLE SPD.....	0MPH
O2S B1 S1.....	0.00V
O2S B1 S2.....	0.00V
SHORT FT #1.....	-0.1%
LONG FT #1.....	1.5%
TOTAL FT #1.....	1.01
O2FT B1 S1.....	-0.1%
FUEL SYS #1.....	0L
FUEL SYS #2.....	UNUSED
MIL.....	ON
O2 LR B1 S1.....	0ms
O2 RL B1 S1.....	0ms
A/C CUT SIG.....	0N
FUEL PUMP / SPD.....	OFF/M,L
EVAP VSV.....	OFF
WVT CTRL B1.....	OFF
IGNITION.....	0
CYL #1.....	0%
CYL #2.....	0%
CYL #3.....	0%
CYL #4.....	0%
BATTERY.....	11.8V
INJECTOR.....	0.0ms
INJ VOL FB.....	1.09
FUEL FB COEF.....	1.01
A/F LEARN.....	1.5%
PURGE LEARN.....	0.0%
KCS FEEDBACK.....	0.0°
REQ ENG POWER.....	OKW
RAM MONITOR.....	INCMP
ENG RUN SIG.....	OFF
ACC RACING SIG.....	OFF
ENG WARM UP SIG.....	ON
ENG RUN PERM.....	PROHIBT
FC STATUS.....	*UNK*
ENG STP LIMIT.....	ISC LRN

**Extended Data List**

INJECTOR.....	0.0ms
IGN ADVANCE.....	5.0deg
CALC LOAD.....	0%
MAF.....	0gm/s
ENGINE SPD.....	0rpm
COOLANT TEMP.....	143.6°F
INTAKE AIR.....	98.6°F
THROTTLE POS.....	50%
VEHICLE SPD.....	0MPH
THROTTLE POS #2.....	0.00V
THROTTLE TARGET.....	0.00V
THROTL OPN DUTY.....	0%
THROTL CLS DUTY.....	0%
THROTTLE MOT.....	OFF
ETCS MAG CLUTCH.....	OFF
+EM.....	OFF
ACCEL IDL POS.....	OFF
THROTL IDL POS.....	OFF
FAIL #1.....	OFF
FAIL #2.....	OFF
THROTL INITIAL.....	0.00V
THROTTLE MOT.....	0.0A
O2S B1 S1.....	0.01V
O2S B1 S2.....	0.76V
VAPOR PRESS.....	731mmHg-a
SHORT FT #1.....	-0.1%
LONG FT #1.....	1.5%
TOTAL FT #1.....	0.50
O2FT B1 S1.....	-0.1%
FUEL SYS #1.....	0L
FUEL SYS #2.....	UNUSED
MIL.....	ON
O2 LR B1 S1.....	0ms
O2 RL B1 S1.....	0ms
A/C CUT SIG.....	OFF
FUEL PUMP / SPD.....	OFF/M,L
EVAP VSV.....	OFF
WVT CTRL B1.....	OFF
IGNITION.....	0
CYL #1.....	0%
CYL #2.....	0%
CYL #3.....	0%
CYL #4.....	0%
MISFIRE RPM.....	0rpm
MISFIRE LOAD.....	0.00g/rev
O2 RL B1 S2.....	0ms
# CODES.....	0
CHECK MODE.....	OFF
40 CYCLES.....	COMPL
SPD TEST.....	COMPL
NSW TEST.....	COMPL
AS TEST.....	COMPL
MISFIRE TEST.....	COMPL
OXS2 TEST.....	COMPL
OXS1 TEST.....	COMPL
#CARB CODES.....	02
OBD CERT.....	OBD2
EGR MON.....	COMPL
O2S(A/FS) HTR.....	INCMP
O2S(A/FS) MON.....	INCMP
A/C MON.....	COMPL
2nd AIR MON.....	COMPL
EVAP MON.....	INCMP
HTD CAT MON.....	COMPL
CAT MON.....	INCMP
BATTERY.....	11.8V
INJECTOR.....	0.0ms
INJ VOL FB.....	1.09
FUEL FB COEF.....	1.01
A/F LEARN.....	1.5%
PURGE LEARN.....	0.0%
KCS FEEDBACK.....	0.0°
REQ ENG POWER.....	OKW
RAM MONITOR.....	INCMP
ENG RUN SIG.....	OFF
ACC RACING SIG.....	OFF
ENG WARM UP SIG.....	ON
ENG RUN PERM.....	PROHIBT
FC STATUS.....	*UNK*
ENG STP LIMIT.....	ISC LRN

Figure 2.12

T072f212

## Using Freeze Frame Data

The Freeze Frame data screen provides information on conditions that were present at the time the DTC was recorded in memory. By recreating the vehicle speed, engine RPM and engine load, as well as other conditions, the technician can verify the customer's concerns.

### NOTE

Print the freeze frame data before deleting the code(s)! The TAS line needs this information in order to assist you.

### Accessing Freeze Frame Data

The Diagnostic Tester screens show a stored DTC. Freeze Frame Data can be viewed when the DTC has an asterisk (\*) next to it.

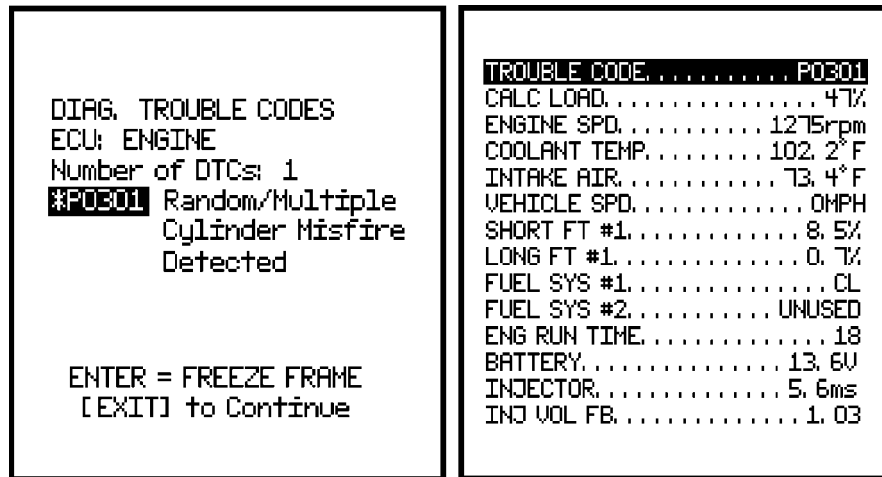

Figure 2.13

T072f213

## Engine Active Tests

The Prius has a unique way of performing a compression test. Using the Diagnostic Tester, go to **HV ECU Active Test**. Select **Cranking Request** on the tester and when ready, turn the ignition key to start. The engine will crank at 250 rpm and will allow for the measurement of compression pressure. If there is lack of power, excessive oil consumption or poor fuel economy, measure the compression pressure.

To perform an Idle Speed inspection activate **Inspection Mode** on the Diagnostic Tester, **Active Test**. Follow the procedures of the tester to check the idle speed, which should be  $1,000 \pm 50$  rpm with the cooling fan OFF.



**WORKSHEET 2-1**  
***Coolant Heat Storage Tank***

Vehicle	Year/Prod. Date	Engine	Transmission
---------	-----------------	--------	--------------

**Worksheet Objectives**

This worksheet will help you diagnose the Coolant Heat Storage Tank and the electric Coolant Heat Storage Water Pump on the 2004 and later Prius.

**Tools and Equipment**

- Vehicle
- Diagnostic Tester
- Repair Manual or TIS
- New Car Features

**Section 1: Components**

1. Raise the vehicle and locate the Coolant Heat Storage Tank.
2. When changing the engine coolant, what drain valve(s) are used to completely drain the system?

---



---



---

3. Locate the water valve. What is the purpose of the water valve?

---



---

**Section 2: System Activation**

1. Even when the engine is cold, why must you be careful when working on the cooling system?

---

---

2. When servicing the cooling system, what should always be disconnected?

---

3. Connect the Diagnostic Tester to DLC3.

4. Select Engine and ECT, Active Test and then Water Pump. Turn on the water pump.

5. When replacing the engine coolant, why does the electric water pump need to be activated with the Diagnostic Tester?

---

6. What will cause DTC P1151 or P2601 to be stored?

---

---

7. List the other cooling system component that can be controlled by the Active Tests.

---

---

---

8. Listen to the water valve as you activate each valve position with the Diagnostic Tester. Did the valve activate to all three positions?

---

Refer to the Technician Handbook to answer the following questions.

9. List the function of each individual valve position below.

---

---

---

10. When diagnosing the valve positions, what are the proper voltage readings to look for?

---

---

---

Return all cars to the original state and return to the classroom.



**Notes**